

# Users' Operation Manual

[ZW series of small-scale wind power generator]

Thank you for purchasing the ZW series of small-scale wind power generators. Please read carefully this "Users' Operation Manual" prior to installation and application for guaranteed safe and normal operation as well as achieving full play of its superior performance; the windmills mentioned in this manual refers to ZW series of wind power generators.

## Manual Contents

1. Product description .....	
2. Package content .....	
3. Windmill installation .....	
4. Installation site .....	
5. Technical specifications .....	
6. Power supply system .....	
7. Precautions.....	

## **1. Product description:**

You should firstly acquaint with the important performances and various specifications of windmills when you decide to purchase windmills. Windmills are made from many parts and components. The design and production of each part and component will affect the quality and operation of the full set of windmill. Users' should understand carefully the following:

- (1) Check whether the rated power of the generator meets the power requirements of the device; if not, DO NOT APPLY to your power consumption load.
- (2) Fan Blades are windmill's most important parts. The physical properties of the fan blades will determine their static and dynamic balance. The quality of the fan blades fully represents that of the entire windmill. Therefore the design and production of fan blades are the most complicated engineering of windmills.
- (3) Should windmills be put into over-loaded operation during super-strong winds or typhoons, this might lead to serious damage or collapse of your windmills. Selection of a set of windmill with restricted operating speed or braking system will guarantee you a safer application with a longer life span.

The ZW series of windmills are of attractive appearance accompanied with excellent, safe, and reliable mechanical and electrical performances. Our generators are of exceptional performance on power generation achieving power of over 100%. The fan blades are optimally designed with state-of-art innovation and workmanship. The weight tolerance of each blade is controlled within 3g. So, they are well balanced with relatively less noisy and more power generated compared to similar products. Our windmills are equipped with over-speed mechanical braking device to stably control windmills within safe rotation speed during super-strong winds and to prevent them from rotating at over speed; they are of very good safety. If our system controller is selected at the same time, then the electrical over-speed resisting system is included, which can be acted as a "double-insurance" system. Our windmills are equipped with current regulating circuit system with direct current (DC) output for a more reliable safety and comply with safety standards of a number of countries.

## 2. Package content:

Please check to ensure the quantity of components are correct against the component checklist prior to installation, and inspect whether the rotor, fan blades, and wind direction regulator are in good conditions:

### Component Checklist

No.	Name of components	Quantity
1	Rotor	1
2	Fan blade	3
3	Wind direction regulator	1
4	Welded flange disks	1
5	Stainless steel hex screws: M10 × 30mm	4
6	Stainless steel nuts: M10	4
7	Gaskets: φ10	4
8	Spring gaskets: φ10	4
9	Users' Operation Manual	1
*10	Windmill system controller	1

Note: “\*” denotes optional product for choice and not included in our STANDARD package if not specified by customers.

**3. Windmill installation:**

Windmill installation must be done by qualified professional or technician. Please DO inspect and make sure all of the joints and bolts are secured, and special attentions should be paid to the balance rotation of fan blade when installed.

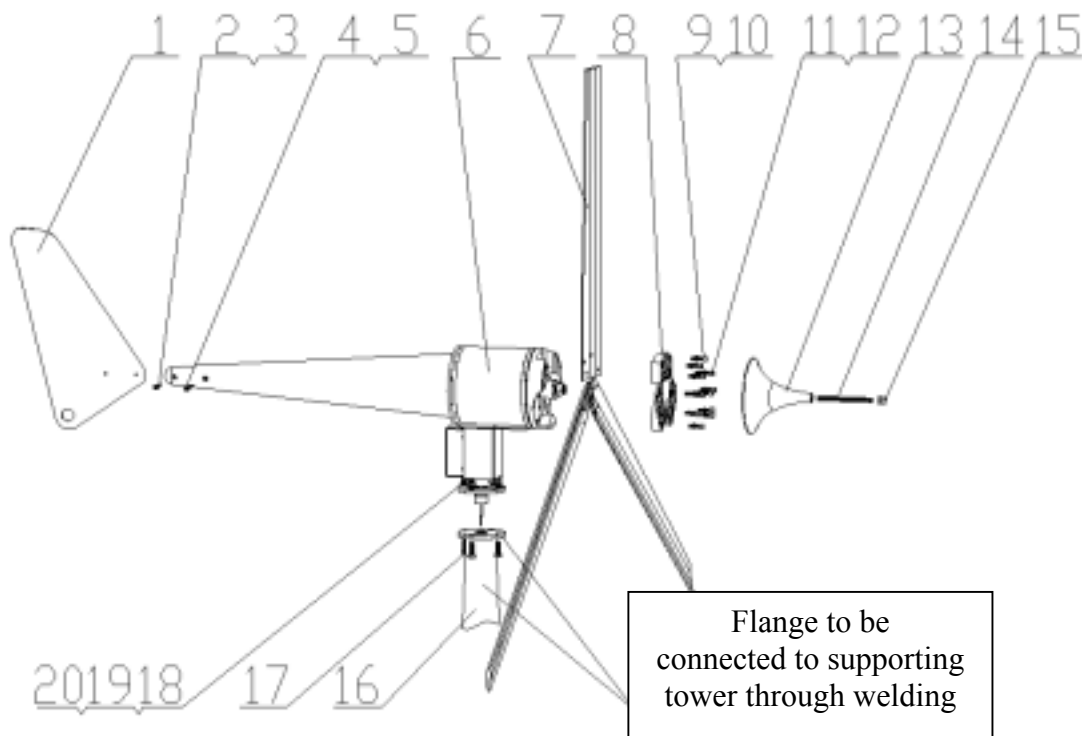

No.	Description	Qty.	No.	Description	Qty.
1	Wind direction regulator	1	11	Hexagonal screws: M8×40	3
2	Disk head screws: M6×40	1	12	Spring gaskets: φ8	3
3	Anti-backing screws: M6	1	13	Nose cone	1
4	Disk head screws: M6×58	1	14	Bolts: M10×140	1
5	Anti-backing nuts: M6	1	15	Nut for nose cone	1
6	Rotor	1	16	Supporting tower (by others)	1
7	Fan blade	3	17	Hexagonal screws M10×30	4
8	Hub	3	18	Nuts: M10	4
9	Hexagonal screws: M8×30	9	19	Spring gaskets: φ10	4
10	Spring gaskets: φ8	9	20	Gaskets: φ10	4

#### 4. Installation site:

The installation site selection is vital to the power generation, safety operation and life span of the windmill. Please refer to the following illustration figure for siting:

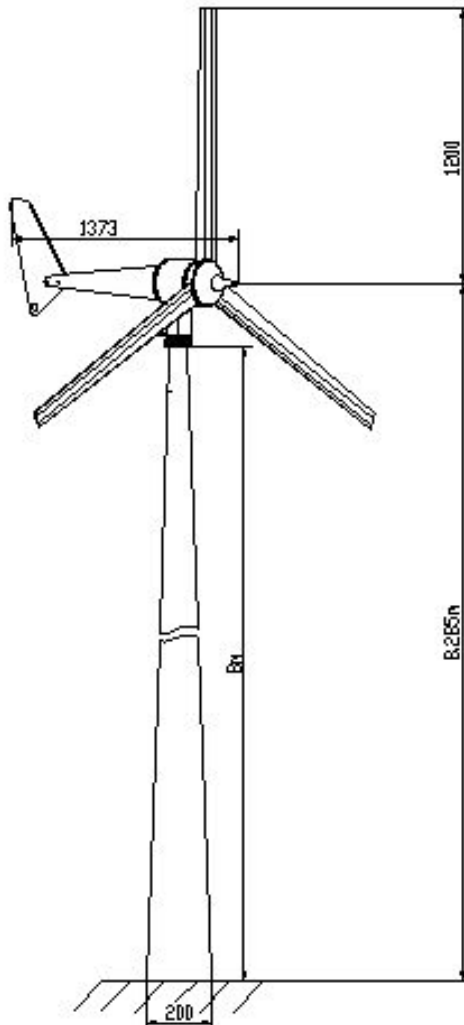

An optimal installation site should provide high average wind speed and minimum turbulence.

- (1) The higher the average wind speed caught, the bigger the power generated (wind power is relatively proportional to the cube of the wind speed, for example, a wind speed at 5m/s will generate almost 2 times the power of 4m/s).
- (2) The windmill will be encountered with severe damages if the installation site is of unstable airflow and serious turbulence. This will be detrimental to windmill's long-term safe operation. The turbulences will greatly reduce the power generated. Therefore, a location with serious turbulences is definitely not a good selection of site.
- (3) The windmill's installation supporting tower must be set as high as possible. Since the higher the tower above the ground level, the greater the wind speed, and the more stable the airflows. The recommended windmill's installation height in flat areas must be higher than 8m.

Trees and various buildings will block airflows, which might result in a delayed flow and turbulence in front of and behind such barriers; thus windmills must be avoided installed in such area.

- (1) Supporting tower must be at least 6m higher than the highest barrier within a radius of 150m;
- (2) Supporting tower must be at least 2 times of the height of the barrier, if the windmill has to be installed right next to the barrier;
- (3) The windmills must be installed at an interval of at least 20m.

**5. Technical specifications:**

**Specification Chart**

Type	ZW-400	ZW-600
Rated voltage: ( V )	12 24 36 48	12 24 36 48
Rated power: ( W )	400	600
Maximum power: ( W )	431	646
Start-up wind speed: ( m/s )	2.3	2.3
Cut-in wind speed: ( m/s )	3	3
Rated wind speed: ( m/s )	12.5	12.5
Braking wind speed: ( m/s )	14	14
Rotation diameter: ( m )	2.2	2.4

**Performance Curve**

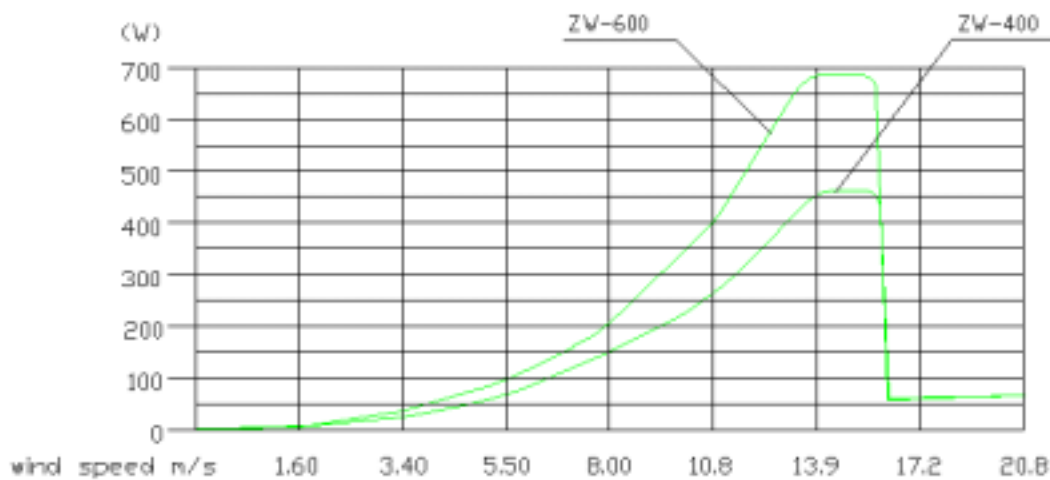

## 6. Power supply system:

For operating equipment of alternating current (AC), you are required to install a 220V (or 110V) 50 Hz (or 60Hz) power inverter with at least 2 sets of 150-200AH / 12V storage battery:

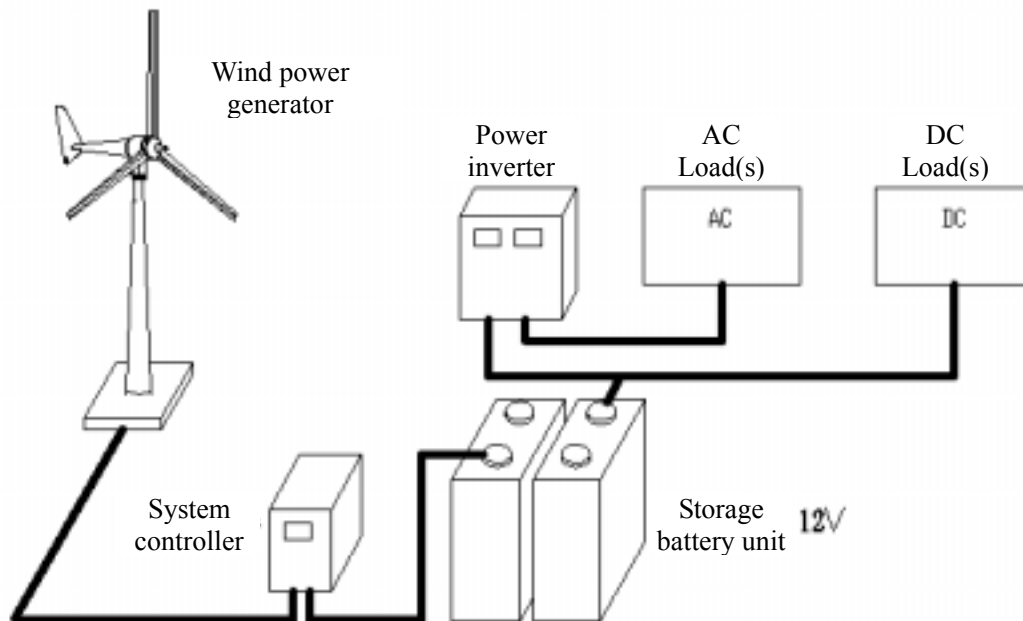

## 7. Precautions:

- (1) Windmills are electricity generating equipments rotating at high speeds; users are supposed to understand thoroughly the windmills' application and relevant maintenance procedures;
- (2) Read carefully the "Users' Operation Manual" and install windmills by qualified technicians;
- (3) Installation site and height of supporting tower must comply with local regulations and code of practices;
- (4) Avoid prolong staying next to windmills and prevent children from reaching;
- (5) Windmills must not be operated with open load in order to prevent fan blades from high-speed rotation;
- (6) Never hit windmills with tools or hard objects;
- (7) Clean and maintain the windmills regularly; annual inspection by professional should be done on various fixing and connecting parts of the windmill;
- (8) Immediately STOP the operation of the windmill should abnormal conditions be found. Call the professional technician for inspection and repair accordingly.
- (9) Please choose only the qualified auxiliary devices like controller, inverter, and storage battery; these devices should be in compliance to user's local standards and requirements.